

LA Audio

M-3

INTEGRATED AMPLIFIER

LA Audio



LA AUDIO ELECTRONIC CO., LTD

9F-1 NO. 37 HSI TSARNG ROAD TAIPEI TAIWAN

WWW.laudio.com.tw

TEL: +886-2-23092540 FAX: +886-2-23091615

READ THIS MANUAL CAREFULLY BEFORE YOU USE THIS
VACUUM TUBE AMPLIFIER KEEP IT FOR FUTURE USE.

WARNING

- To prevent fire or shock hazards DO NOT expose the unit to rain or moisture.
- To avoid electrical shock, DO NOT open the case. Refer to certificated professional only. For your safety, please pay attention to the marks of safety and the advise of preventing electricity.

Advice of LA-AUDIO

- This machine is designed based on original circuit of vacuum tube, and all of compounds were designed based on the requirement of the high-voltage as well. The modification is not allowed for any reason, we will not accept any modified machine for the warranty.

Operating Instruction

Before operating the machine, please check the voltage whether conforms to your demands. Please select your needed voltage for 230V or 115V. Plug the electron tube to the specified outlet according to following drawing number. Connect the loudspeaker and the output terminal of the machine and the signal cord at the same time. Then turn on the machine, if there is any anomalism occurred while the machine is operating, (EX: smoking, peculiar smell and vacuum.... etc) please turn off the power and contact to your dealer or our company immediately.

CONTROLS

FRONT PANEL

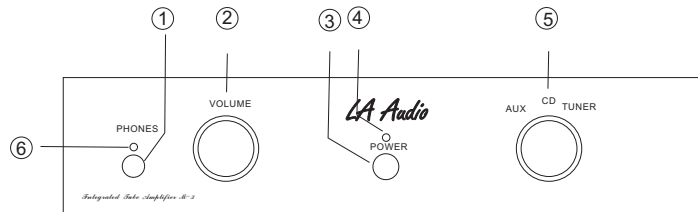

1. EARPHONE JACK
2. VOLUME CONTROL
3. POWER SWITCH
4. INDICATOR
5. SIGNAL SELECT SWITCH
6. SENSOR

REAR PANEL

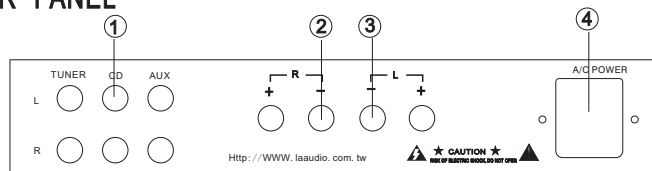

1. RCA SIGNAL JACK
2. LEFT CHANNEL OUTPUT JACK
3. RIGHT CHANNEL OUTPUT JACK
4. AC POWER

CONNECTION

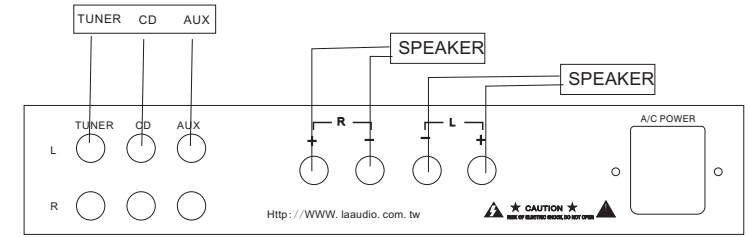

VACUUM TUBE POSITION

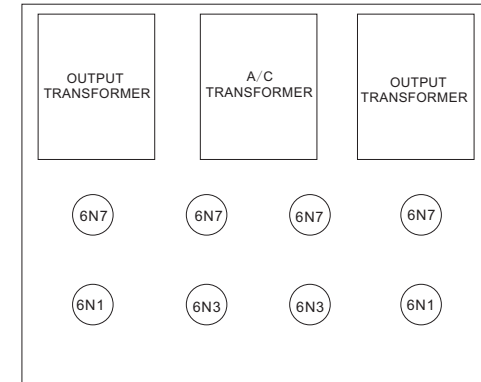

SPECIFICATIONS

1. POWER OUTPUT: 25W×2
2. FREQUENCY RESPONSE: 10Hz-30kHz
3. SIGNAL TO NOISE RATIO: ≥85dB
4. OUTPUT IMPEDANCE: 4Ω-8Ω
5. HARMONIC DISTORTION: ≤1.5%
6. POWER CONSUMPTION: 100W
7. TUBE: 6N7×4 6N1×2 6N3×2
8. DIMENSIONS W×D×H (CM) : 31×29×13.5
9. POWER: 115V/60Hz 220V/230V/50Hz
10. WEIGHT: 9Kg